

# Manitowoc Crane Group

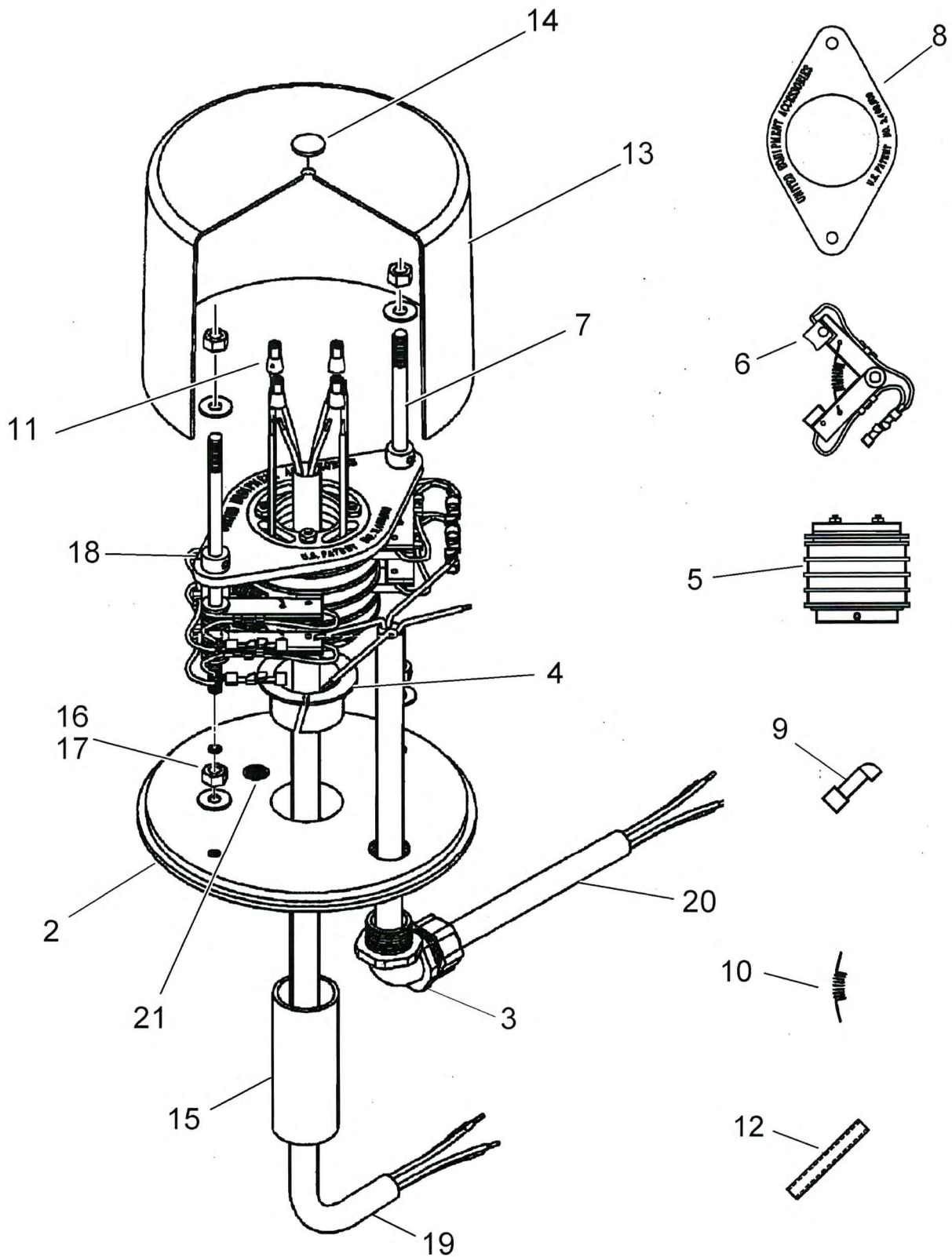

7753100037

(SHEET 3 OF 4)

Page 170

# Manitowoc Crane Group

SUPERSTRUCTURE HARNESS						
HARNESS NUMBER	SLIP RING #	CON-NEC-TOR	CONN. CAVITY	CABLE	CABLE CONDUCTOR COLOR	TERMINAL (SEE CHART)
1	01	A	1	---	---	R
	02	A	2	---	---	R
	03	A	3	---	---	R
	04	A	4	---	---	R
	05	A	5	---	---	R
	06	A	6	B	SHIELD	R
	07	A	7	B	BLACK	R
	08	A	8	B	RED	R
	09	A	9	A	SHIELD	R
	10	A	10	A	BLACK	R
	11	A	11	A	RED	R
---	A	12	---	---	T	
2	12	B	---	---	---	Q
	13	C	---	---	---	Q
	14	D	---	---	---	Q
	15	---	---	---	---	N
CARRIER HARNESS						
4	01	E	1	---	---	S
	02	E	2	---	---	S
	03	E	3	---	---	S
	04	E	4	---	---	S
	05	E	5	---	---	S
	---	E	6	---	---	T
	06	F	1	D	SHIELD	R
	07	F	2	D	BLACK	R
	08	F	3	D	RED	R
	09	F	4	C	SHIELD	R
	10	F	5	C	BLACK	R
11	F	6	C	RED	R	
5	12	G	---	---	---	P
	13	H	---	---	---	P
	14	J	---	---	---	P
	15	---	---	---	---	N

CONNECTORS/TERMINALS/BOOTS				
CONNECTOR/TERMINAL/BOOT	GROVE PART NUMBER	PART DESCRIPTION	QTY	PART NUMBER
A	7892001012	RECEPT 12P FLANGE MOUNT REQUIRES BOOT "K"	1	56
B,C,D	7709000876	PLUG 1S-4, NO BOOT REQ'D	3	41
E	7709000883	PLUG 6S, REQUIRES BOOT "M"	1	42
F	7892000824	RECEPT-6P, REQUIRES BOOT "L"	2	43
G,H,J	7892000939	RECEPT-1-4P, NO BOOT REQ'D	3	44
K	7172000551	BOOT FOR 12P RECEPTACLE	1	45
L	7172000564	BOOT FOR 6P RECEPTACLE	1	46
M	7172000565	BOOT FOR 6S PLUG	1	47
N	7345242101	3/8" DIA EYELET, 6 GA	2	48
P	7689000813	PIN (4), 6GA NICKEL	3	49
Q	7826000095	SOCKET (4), 6GA NICKEL	3	50
R	7689002053	PIN (16-18 GA), GOLD PLATED	17	51
S	7826100004	SOCKET 16-18 GA GOLD PLATED	9	52
T	7689000503	SEAL PLUG (16-12 GA)	8	53
U	7709000936	PLUG 4S, REQUIRES BOOT "V"	1	54
V	7172000567	BOOT FOR 4S PLUG	1	55

ITEMS NOT SHOWN  
NBR 22  
NBR 37

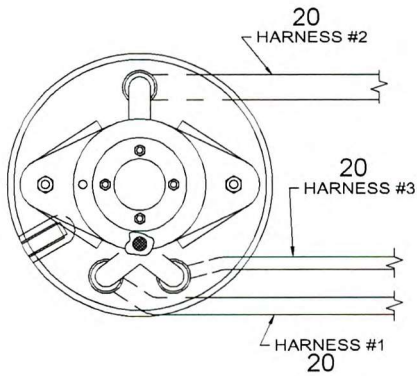

TOP & SIDE VIEW OF SWIVEL TO SHOW HARNESS ROUTING AND LOCATION COVER OMITTED FOR CLARITY

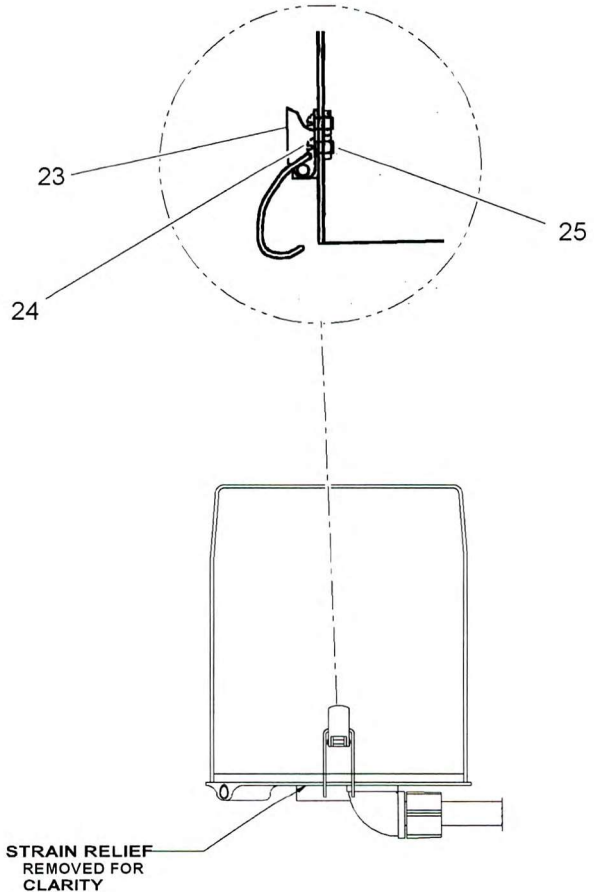

# Manitowoc Crane Group

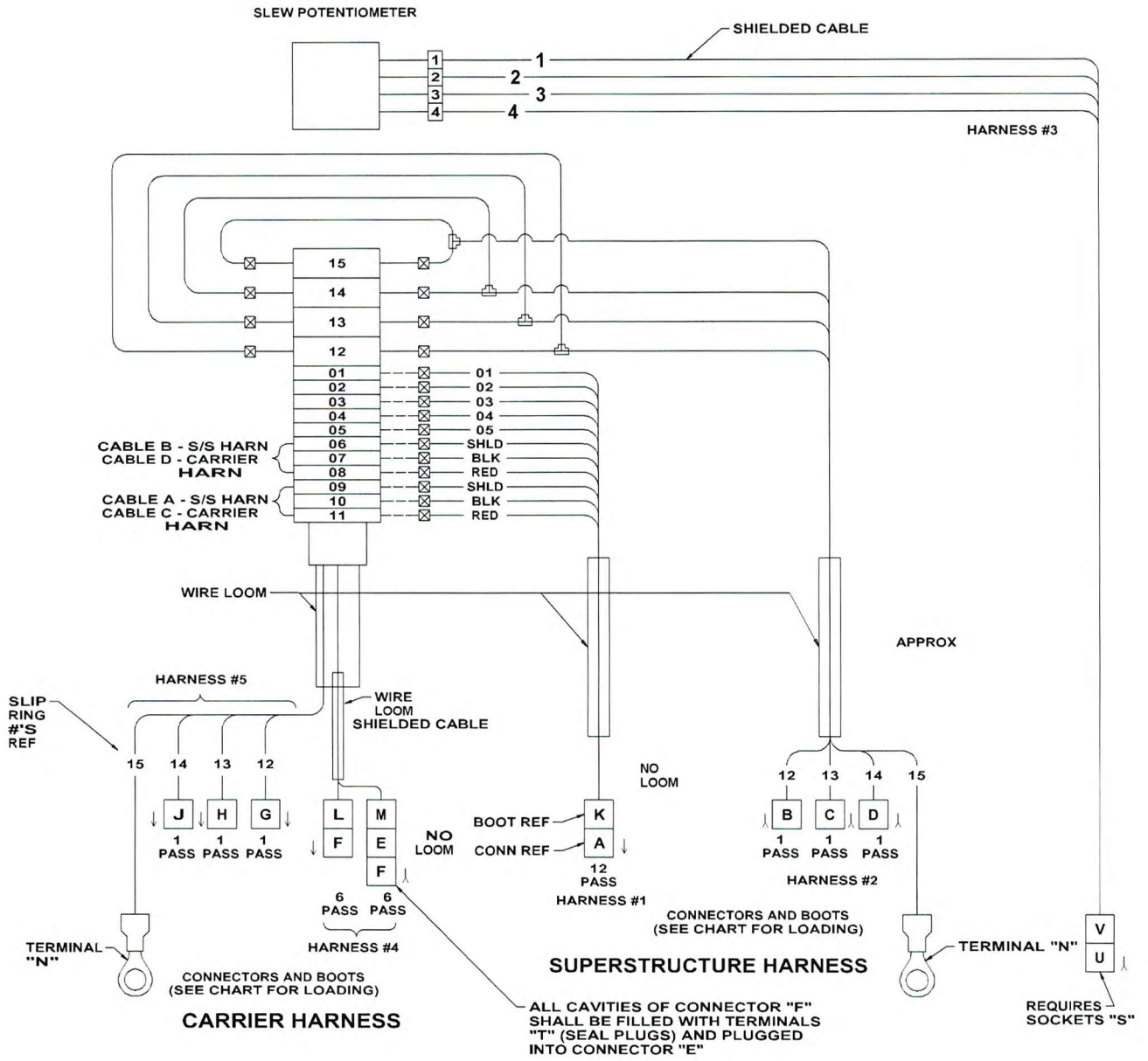

7753100037

(SHEET 1 OF 4)